

M102003-M102004

ROTATING CATTLE RITUAL BOX

Description:

The rotary box is a machine designed for the ritual slaughter of cattle. This box is recommended for the slaughter of animals weighing between 400 and 600 kg on foot. Production is nominal and estimated, depending on the configuration of the entry chute, the correct combination of light inside and outside the box, the cleaning of blood during slaughter, and the operator's handling skills.

All these factors determine effective production. Mecanova guarantees a machine cycle time of 85 seconds; effective production will depend on the factors mentioned above.

This is an individual model, i.e. it works on one animal at a time. The box has several systems for pushing, restraining and securing the animal, and the following process is carried out:

1. Once the animal is inside, it is forced to stick its head out the front with the rear push door.
2. In a second movement, the space is reduced laterally, holding the upper part at shoulder level.
3. The front guillotine door closes, holding the head in place.
4. The display shows the neck for cutting.
5. The box rotates 180° at the operator's convenience for cutting.
6. Once the operator or veterinarian considers the bleeding sufficient, the animal is released and the exit door is opened.

The box's rotary movement is electric, powered by a gear motor. The internal clamping movements are carried out by hydraulic actuators.

The equipment includes a hydraulic power unit with oil tank. The initial oil charge and the hydraulic installation from the power unit to the box are not included in the base price.

The machine is operated by means of a portable 24V control panel, so that the operator can operate it from the most convenient point, without the animal seeing them, or if it does see them, without frightening it. Normally, the ideal location is a few metres in front of the box (includes 6m connection hose).



Dimensions:

- Length 2800 mm (interior 2500 mm)
- Width diam. 2000 mm (interior 800 mm)
- Height box 2500 mm,
- Entrance door: 4000 mm.
- Weight 2800 kg.

Technical data:

- Slaughter box for Halal and/or Kosher rites with two manufacturing options: hot-dip galvanised S275 JR iron or AISI-304 stainless steel. All tubular profiles are structured, and the sheets are thicker than 8 mm and 10 mm.
- Equipped with:
 - Pneumatically operated guillotine entrance door.
 - Rotating box with rear push door.
 - Side push and clamping door.
 - Side exit door.
 - Guillotine-type front door for head trapping.
- Neck bib with a design that allows Halal or Kosher cutting.
- Hydraulic cylinders connected by rigid stainless steel piping
- 3kW electric gear motor with brake / braking torque 40kW
- 4HP hydraulic power unit
- Electrical protection and control panel with PLC and frequency converters
- 24V control with 8m cable to panel

DEMOSTRATION VIDEO 1

DEMOSTRATION VIDEO 2

DEMOSTRATION VIDEO 3

Options:

- Animal exit
 - Turned position (production of 50 cattle/hour). This has the advantage of allowing better exit for animals with long horns.
 - Entry position (production 40 cattle/hour). Can be used in traditional mode without rite or with rite, but without turning, with a production of up to 85 animals per hour.
 - Hydraulic or pneumatic clamping option.
 - Double push door for working with small and large animals.

Requirements:

- Simple benches need to be built to position the box.
- We recommend purchasing our reception table/cradle.
- We recommend building a blood collection hopper below ground level, in front of the box and the table covered by Tramex for operator transit.
- The plans for the benches and hopper are provided by Mecanova.



Documentation

The following documentation will be delivered with the machine:

- CE guarantee certificate
- Manual of use and maintenance
- List of recommended spare parts
- Drawings of machine parts referenced for the maintenance department
- Electrical and/or hydraulic diagrams

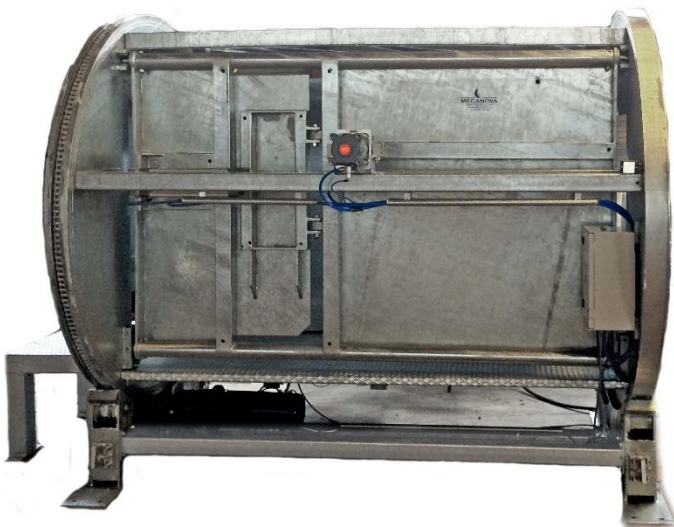

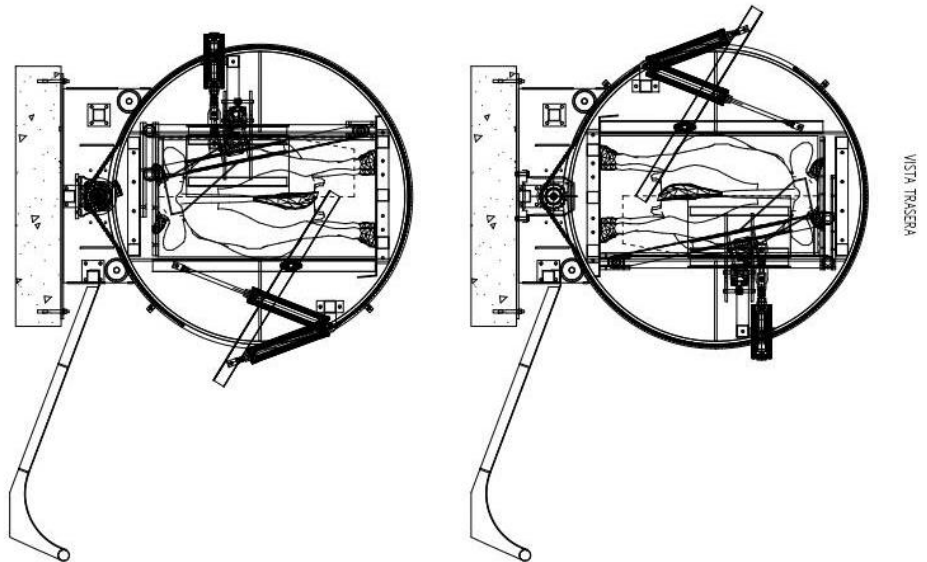
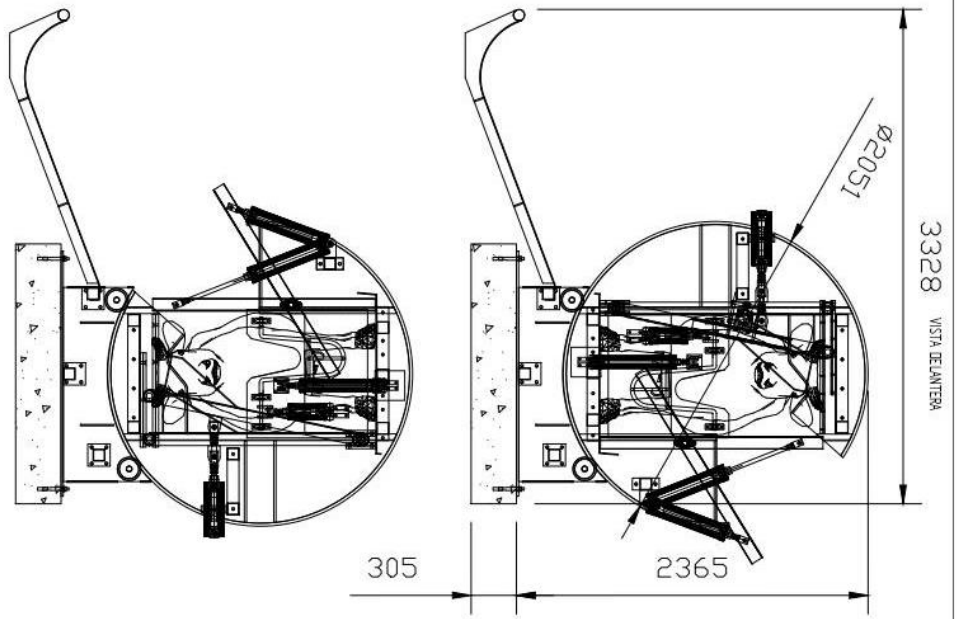

				MODIFICACION _____ _____ _____	
Estado: Diseñado Verificado Emitido	Proyecto: Cliente: Ubicación: Ref.: Proyecto	Descripción: BOX RITUAL BOVINO SALUDA DERECHA	Organismos: _____ _____ _____	Fecha: _____ _____ _____	Autor: Firmado Digital: Date de Emisión: Número: M1220110030100
			Hoja: 01		



